

STATICKÉ POSÚDENIE.

STAVBA: **PRESKLENNÁ STRIEŠKA „GS/PR-R3-M12-set/glass“**

STUPEŇ: **STATICKÝ POSUDOK**

ZÁK. Č.: **11-07-67/R3**

1) ZÁKLADNÉ ÚDAJE:

Presklenná strieška „GS/PR-R3-M12-set/glass“ pozostáva z 2ks kĺbových podpôr a 2ks kĺbových tiahiel. Použité prierezy sú priemeru: tiahlo - 12mm a kĺb - 8mm, materiál $R_{p0,2} = 190\text{MPa}$. Sklo 1,0x1,4m je hrúbky 2x6(8)mm + fólia (GS/12,76-140x100-VSG/ESG). Kotvenie do stien je podľa použitého materiálu v stenách (tehla, betón) – rieši sa na stavbe.

Únosnosť jedného kĺbového tiahla je 2,5kN (250kg), je to únosnosť kĺbu. Celkové zaťaženie setu (vlastná váha + sneh) je 4,0kN, na jedno tiahlo (podporu) je to 1,0kN < 2,5kN. Systém presklenej striešky vyhovuje.

2) ZÁVER:

Systém presklenej striešky (podpory a tiahlo) vyhovuje statickému výpočtu, platným normám a technickým požiadavkám. Pri realizácii je potrebné dodržiavať doporučený systém kotvenia a montáže výrobcom prvkov a platné predpisy.

Prešov, 10.2013

Ing. POLÁK Jozef



SKRUTKY NAMÁHANÉ ŠMYKOM

Odolnosť proti strihu : Ø8mm

$$F_{V,Rd} = 0,5 \cdot f_{ub} \cdot A_s / \gamma_{M2}$$

$$F_{V,Rd} = 0,5 \cdot 190 \cdot 50,27 / 1,25$$

$$F_{V,Rd} = 3,82 \text{ kN}$$

- f_{ub} (medza pevnosti materiálu)
- A_s (plocha spojovacieho prostriedku namáhaná ťahom)
- γ_{M2} (parciálny súčiniteľ)



STATIC EVALUATION

SITE: **GLASS SHED "GS/PR-R3-M12-set/glass"**

LEVEL: **STATIC EVALUATION**

CUSTOMER NO.: **11-07-67/R3**

1) GENERAL INFORMATION:

The glass shed "GS/PR-R3-M12-set/glass" consists of 2 pieces of hinged supports and 2 pieces of hinged rods. Used intersections are of diameters: rod – 12 mm and hinge – 8 mm, material $R_{p0,2} = 190$ MPa. Glass 1,0 x 1,4 m is of 2 x 6 (8) mm thickness + foil (GS/12,76 – 140 x100 – VSG/ESG). Anchoring into the walls is according to the materials used in the walls (brick, concrete) – this is dealt with on the site.

Load capacity of one hinged rod is 2,5kN (250 kg), this is the load of the hinge. Total loading capacity of the set (own weight + snow) is 4,0kN, it is 1,0 kN < 2,5 kN for one rod (support). The system of glass shed is sufficient.

2) CONCLUSION:

The system of the glass shed (support and rod) is sufficient according to the static calculation, valid norms and technical requirements. It is necessary to follow the system of anchoring and montage advised by the producer and valid regulations during realization.

Prešov, 10.2013

Ing. POLÁK Jozef

STATIC STUDIO s.r.o., PREŠOV

Ing. POLÁK Jozef

11-07-67/R3



BOLTS UNDER SLIP STRESS

Resistance against cut: $\varnothing 8$ mm









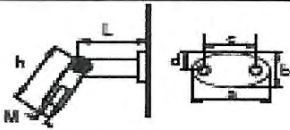

$$F_{v1Rd} = 0,5 \cdot f_{ub} \cdot A_s / \gamma_{M2}$$

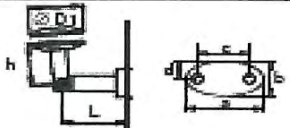
$$F_{v1Rd} = 0,5 \cdot 190 \cdot 50,27 / 1,25$$

$$F_{v1Rd} = 3,82 \text{ kN}$$

- f_{ub} (measure of the material firmness)
- A_s (area of linking agent under stress of strain)
- γ_{M2} (partial coefficient)

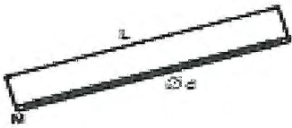

SET		GS/PR-R3-M12							
		A/PR70x40-M12							
AISI304		Dimensions	M	L	h	a	b	c	d
		mm	12	70-78	60	70	40	48	20
		+							
		A/PR70x40-80							
AISI304		Dimensions	∅ D1	h	L	a	b	c	d
		mm	58	50	70-78	70	40	48	20
		+							
		A/PR-60-M12							
AISI304		Dimensions	∅ D1	M	h	L			
		mm	60	12	50	60			
		+							
		A/PR12-1000-M12							
AISI304		Dimensions	M	L	∅ d				
		mm	12	1000	12				

